

**MULTI-STOREY CAR PARK
DRAINAGE CHANNEL
MEARIN PG EVO
THE ORIGINAL -
REDEFINED**

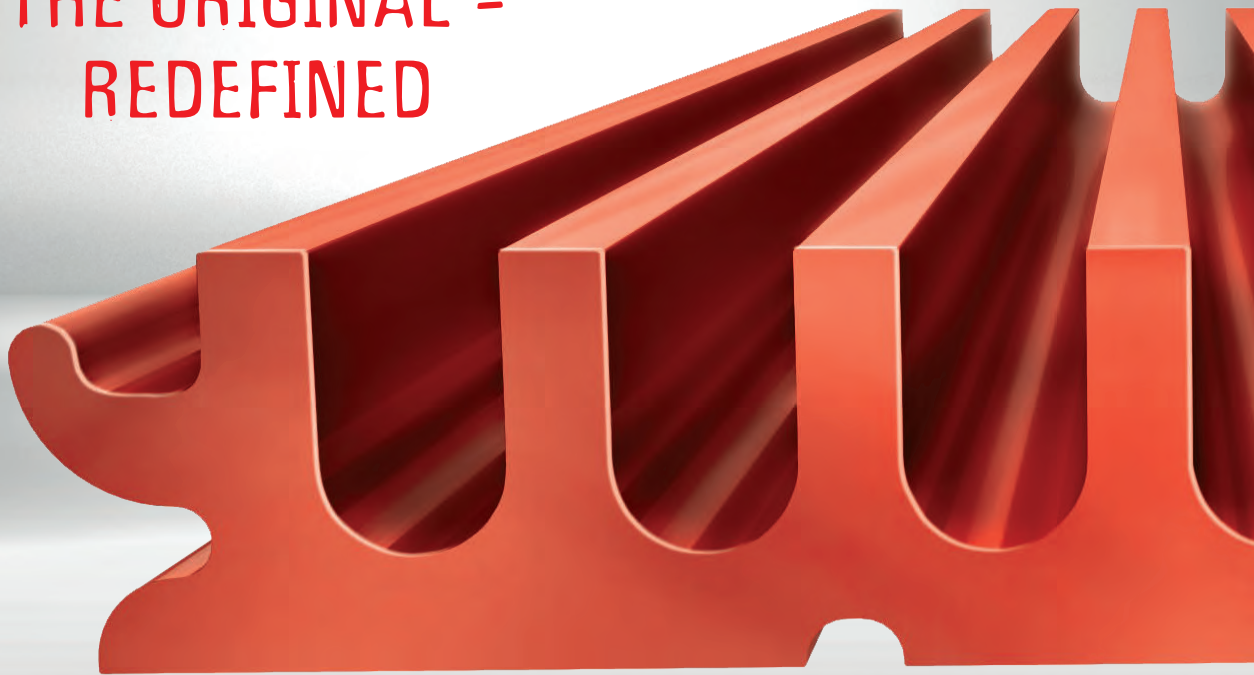

MULTI-STOREY CAR PARK DRAINAGE CHANNEL MEARIN PG EVO

LIGHT, ECONOMICAL, SAFE

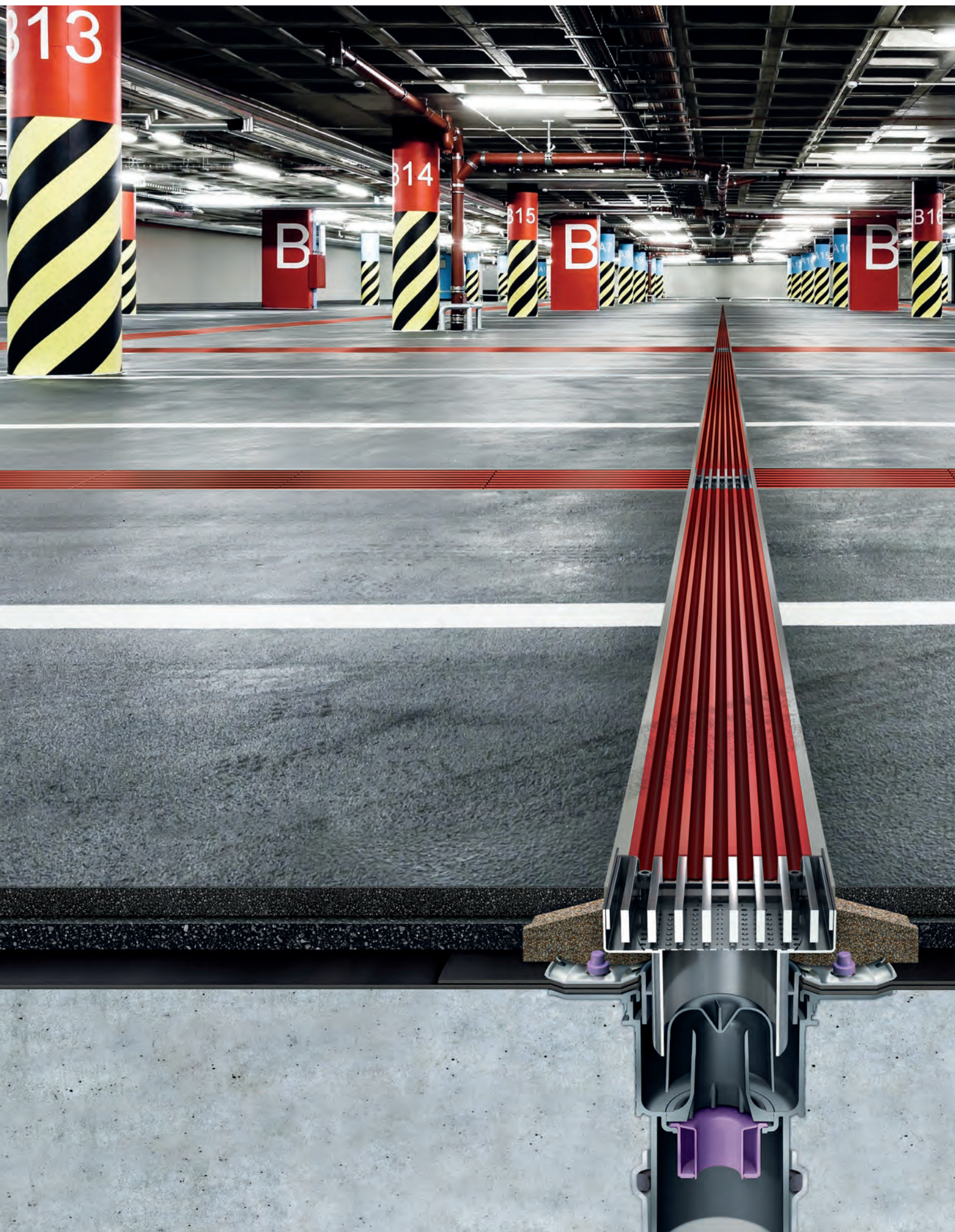



**MULTI-STOREY CAR PARK
DRAINAGE CHANNEL
MEARIN PG EVO
CUSTOM COLOURS
EXCEPTIONALLY STABLE
EXTREMELY DURABLE**

Benefits at a glance

- ✓ Fully fledged system solution
- ✓ Custom colour options
- ✓ Low noise level
- ✓ Easy to install
- ✓ Glass-fibre-reinforced composite
- ✓ Corrosion-free
- ✓ Easy to clean
- ✓ Total height 30 mm
- ✓ Absolutely tight
- ✓ Barrier-free



Barrier-free

- ✓ Full wheelchair accessibility thanks to the maximum slot width of 13 mm
- ✓ Same height as the surrounding surface

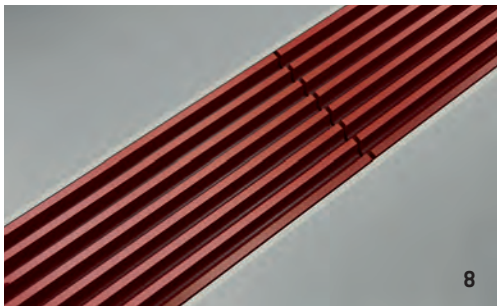

Absolutely tight

- ✓ With sealing flange for OS floor coating or mastic asphalt
- ✓ Standard-compliant (EN 1433) because the joint can be accessed easily for inspection
- ✓ Optimal sealability because the joint is also freely accessible from above after installation

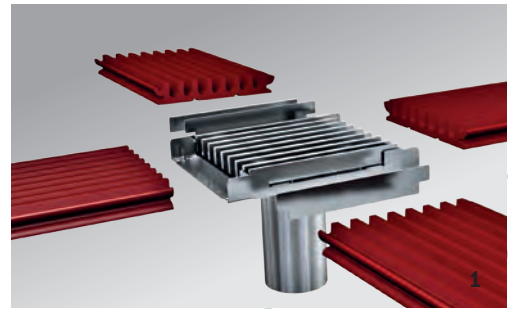

Fully fledged system solution

- ✓ Architecturally demanding solution for draining multi-storey car parks and underground garages
- ✓ Extensive array of accessories: intersection elements, end caps and floor gully made from stainless steel



Easy to install

- ✓ Low total height: no cavities in the floor
- ✓ Also suitable for refurbished buildings because the flat design is independent of the system previously installed
- ✓ Lengths of up to 3 metres mean fewer edges
- ✓ Aesthetically pleasing solution

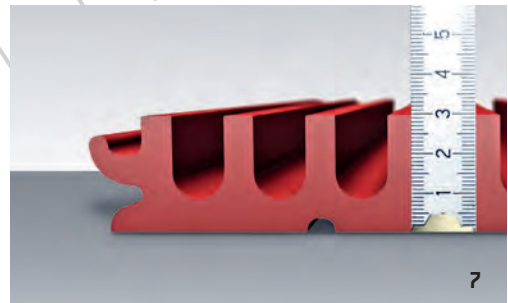

Total height 30 mm

- ✓ Suitable for floor structures with screed concrete or single/multi-layer mastic asphalt
- ✓ No impact on reinforcement or statics
- ✓ Flatter floor structures possible
- ✓ Easier and quicker installation of the reinforcement
- ✓ Optimal rehabilitation solution
- ✓ Ideal for rehabilitating ditched channels



Custom colour options on request

- ✓ Free choice of colours if the total length ordered exceeds 1,000 m
- ✓ Optimal integration in traffic management systems



Glass-fibre-reinforced composite

- ✓ Sealable, resistant to de-icing salt and chemicals, suitable for all loading classes up to F 900
- ✓ Non-wearing and weatherproof
- ✓ High lateral compressive strength
- ✓ Mirror-smooth surface
- ✓ Similar linear expansion to reinforced concrete
- ✓ Capillary-free material

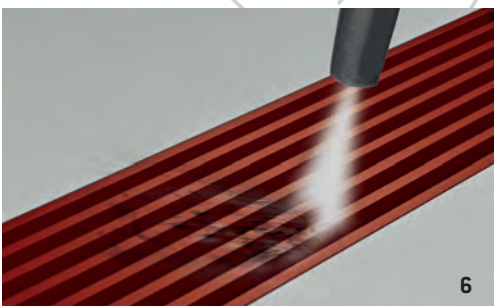

Easy to clean

- ✓ Visual inspection for soiling suffices because there are no complicated gratings to remove
- ✓ Easy cleaning thanks to the free drainage channel cross section with no gratings or cross bars
- ✓ Freely accessible from above



Low noise level

- ✓ Low noise level because there are no moving parts in the entire PG EVO system
- ✓ No complaints from residents due to gratings rattling when driven over

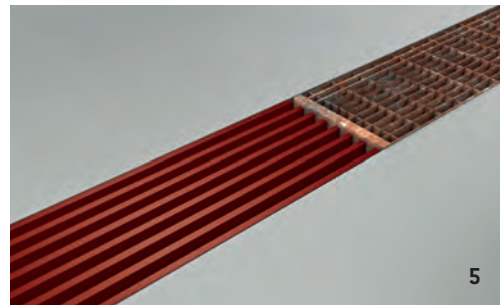

Corrosion-free

- ✓ Resistant to salt, oil and petrol
- ✓ Drainage channel body is completely monolithic and made from glass-fibre-reinforced composite, therefore no rust-prone metal parts
- ✓ Durable aesthetic appeal thanks to the robust, non-rusting material

INSTALLATION INSTRUCTIONS

INSTALLATION IN FLOORS AND BASE PLATES WITH MEARIN PG EVO MULTI-STOREY CAR PARK DRAINAGE CHANNELS (Pic.1) AND GULLY ELEMENT (Pic.2) DIA. 110 AND COMPRESSION SEALING FLANGE

Construction in 2-layer mastic asphalt (2 x 30 mm) and 2nd sealing layer in construction type 1a, in accordance with DIN 18532-1, 8.4.9.4.2, Fig. 19

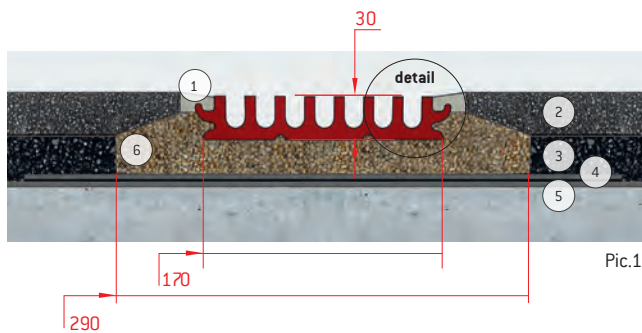

Pic.1

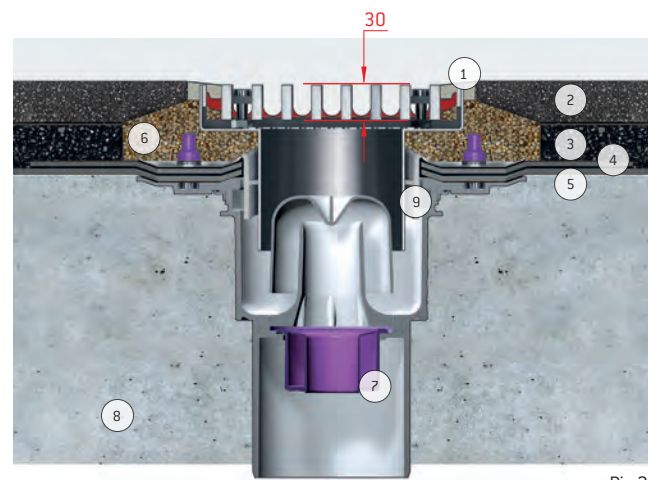

Pic.2

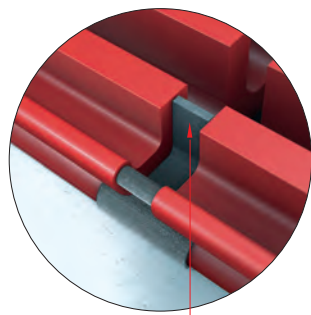

Separating flaps of connecting elements

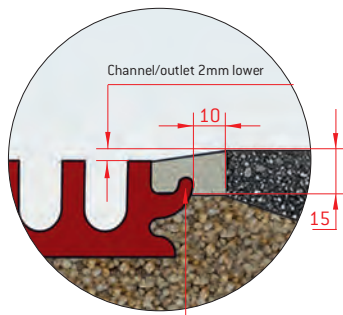

Product advantage: factory-preformed groove for better adhesion

- 1- Joint sealant type N1 in accordance with ZTV Fug-StB15, 2.1.1, Table 2/Fig. 7/ p.26 W/D 10/15 mm
- 2- 30 mm AS mastic asphalt screed wear layer in accordance with DIN EN 13813/ hardness class AS IC 40
- 3- 30 mm AS mastic asphalt screed protective layer
- 4- 5 mm polymer bitumen sheeting with overlaying reinforcement, in the area of the channel 2-layer, e.g. SikaBit CE
- 5- Primer/sealing on epoxy resin basis, e.g. Sika Ergodur-500 Pro
- 6- Epoxy resin drainage mortar, e.g. Sakret EPD, use category N3
- 7- Compression sealing flange DN 100 with odour seal and fire-kit, e.g. Kessel
- 8- Structural concrete
- 9- Mortar barrier

INSTALLATION WORK STEPS MEARIN PG EVO MULTI-STOREY CAR PARK DRAINAGE CHANNELS:

- I. Place drainage channel/gully on mortar bed.
- II. Set lateral joint on drainage channel with steel rail or foam strip
- III. Cast lateral mastic asphalt surfaces and allow to harden.
- IV. Remove separating flaps of connecting elements. (Pic.1 and Pic.4)
- V. Grout drainage channel joints to be permanently elastic.

These installation instructions are generally applicable suggestions. Special requirements on the installation of the drainage channels due to local circumstances must be specified by the planners. The manufacturer's specifications with regard to product selection must be observed.

INSTALLATION IN FLOORS AND BASE PLATES WITH MEARIN PG EVO MULTI-STOREY CAR PARK DRAINAGE CHANNELS – VERSION 1 OS

Construction with OS floor coating without 2nd sealing layer in construction type 1b, in accordance with DIN 18532-1, 8.4.9.4.2, Fig. 22

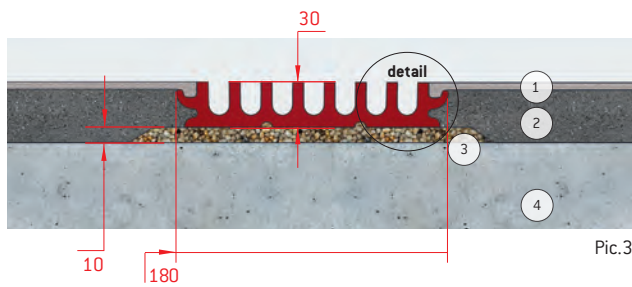

Pic.3

Product advantage: factory-preformed groove for better adhesion

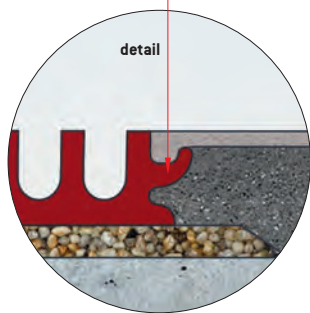

INSTALLATION IN FLOORS AND BASE PLATES WITH MEARIN PG EVO MULTI-STOREY CAR PARK DRAINAGE CHANNELS – VERSION 3 OS

Construction with OS floor coating without 2nd sealing layer in construction type 1b, FLK, in accordance with DIN 18532-1, 8.4.9.4.2, Fig. 22

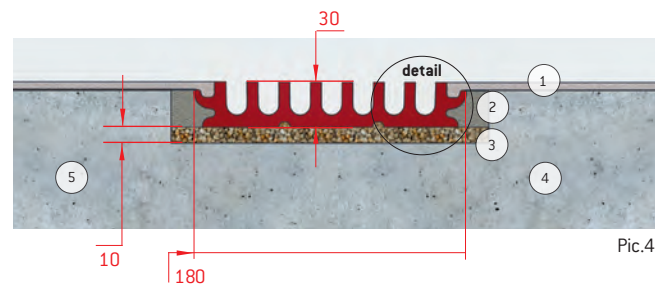

Pic.4

ADVANTAGES MEARIN PG EVO MULTI-STOREY CAR PARK DRAINAGE CHANNELS

- ✓ Drainage channel installation height only 30 mm lower ► floor and base thickness
- ✓ Channel length 3 metres ► fewer edge seals

- 1- OS floor coating screed, e.g. Sika CarDeck systems
- 2- Polymer-modified screed
- 3- For drainage channel bonding, e.g. Sikadur-31 CF on epoxy resin basis
- 4- Structural concrete

- 1- OS floor coating screed, e.g. Sika CarDeck systems
- 2- Plastic-modified grout, non-shrinking, e.g. Sikadur-42HE
- 3- For drainage channel bonding, e.g. Sikadur-31 CF on epoxy resin basis
- 4- Structural concrete
- 5- Width of opening: 220 mm Depth of opening: 35 mm

These installation instructions are generally applicable suggestions. Special requirements on the installation of the drainage channels due to local circumstances must be specified by the planners. The manufacturer's specifications with regard to product selection must be observed.



MULTI-STOREY CAR PARK DRAINAGE CHANNEL MEARIN PG EVO

Whatever the construction type, may it be with concrete and OS coating or with mastic asphalt the MEARIN PG EVO fits into any multi-storey or underground car park building.

The MEARIN PG EVO can installed very easily, thanks to its comb design, its low heights and the absence of gratings.

MEARIN PG EVO fits every multi-storey car park construction type

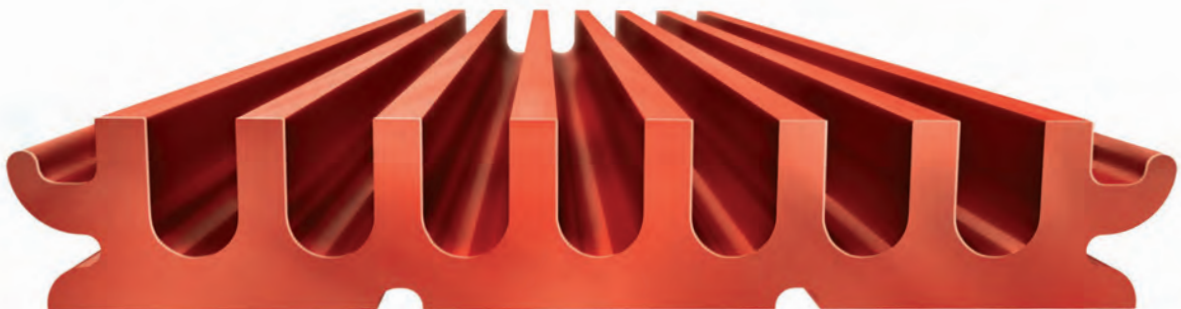
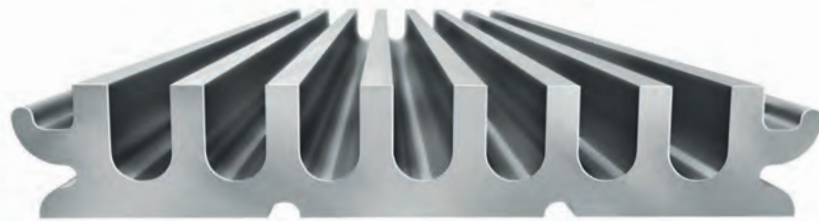

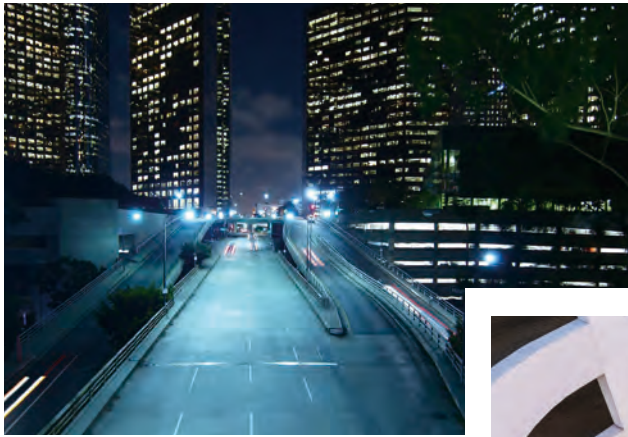

PARKING EXISTS

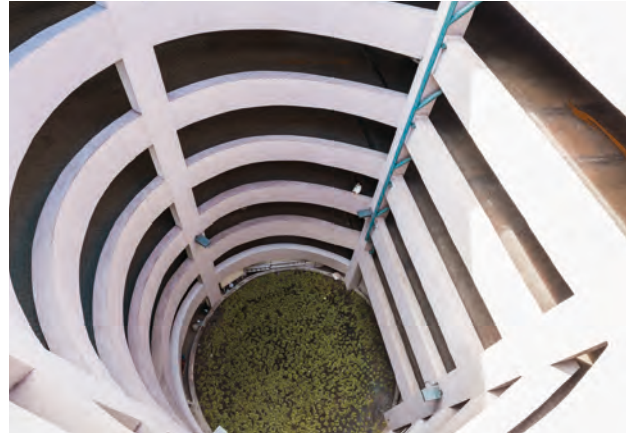

MULTI-STORY CAR PARCS



CAR DEALERSHIPS

MEARIN PG EVO

APPLICATION AREAS



INTEGRATION INTO THE GUIDANCE SYSTEM POSSIBLE



UNDERGROUND CAR PARKS



COVERED PARKING AREAS

DISCOVER THE RANGE OF MEA DRAINAGE SOLUTIONS



MEADRAIN PG
Drainage system
for multi-storey car
parks



MEATEC
Professional drainage
system for façades
and terraces



MEARIN
Professional lightweight
drainage system made
of GRP



MEADRAIN
Professional drainage
systems for challenging
projects



BUILDING SUCCESS

MEA Water Management / Sudetenstraße 1 / D-86551 Aichach / www.mea-group.com / www.parkhausrinne.de
Geschäftseinheit der MEA Bautechnik GmbH